



GEAR PUMPS



JUNIOR GEAR PUPPY

Gear pumps are ideal for the transfer of hydraulic and light oils, water and Diesel fuel. They are 12 or 24V DC powered making them suitable in automotive, bus and truck applications.

FEATURES

- Medium duty pumps for general purpose use.
- Maximum viscosity 150 Cs
- Inlet filter included
- Simple design means fewer wearing parts
- 3.2 gpm (12.1 lpm) output @ 16.4ft (5m) head
- Self priming to 3 ft (1.0m)
- Ideal for water, oil and diesel transfer



DIMENSIONAL DRAWING

UNLESS OTHERWISE STATED DIMENSIONS IN [] ARE IN MM.

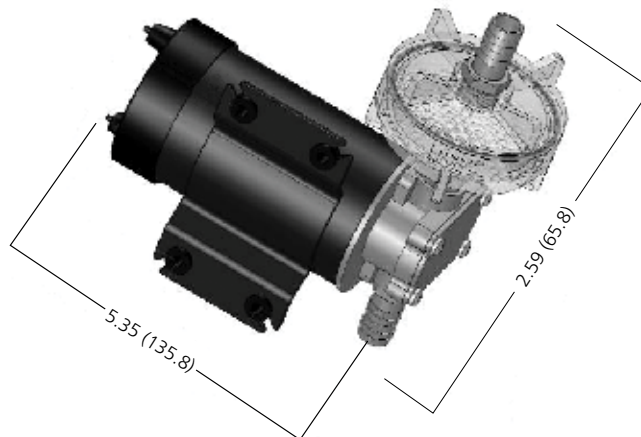

MODELS

MODEL #S	CE	VOLTAGE
23220-2012	Yes	12Volts DC
23220-2024	Yes	24Volts DC



GEAR PUPPY

FEATURES

- Medium duty pumps for general purpose use.
- Maximum viscosity 150Cs
- Inlet filter Included.
- Simple design means fewer wearing parts.
- 6.9 gpm (26.1 lpm) @ 16.4ft (5m) head
- Ideal for water, oil and diesel transfer.
- Meets USCG 183.410



DIMENSIONAL DRAWING

UNLESS OTHERWISE STATED DIMENSIONS IN [] ARE IN MM.

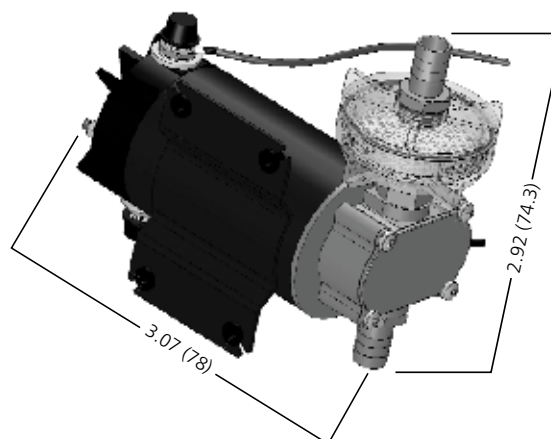

MODELS

MODEL #S	CE	VOLTAGE
23230-2012	Yes	12Volts DC
23230-2024	Yes	24Volts DC



HY~LINE SUPER HYGIENIC POSITIVE DISPLACEMENT PUMP

ITT Jabsco's latest rotary positive displacement pump incorporates the very latest in hygienic design concepts in order to fulfill the ever increasing customer demands for improved cleanability, hygiene and sterilize ability. This 316 Stainless Steel design uses a bi-wing rotor, which encompasses the very best features of tri-lobe rotor pumps and circumferential piston pumps. The pump is built upon ITT Jabsco's 40 year experience of producing and supplying their Flexible Impeller and 24 Series rotary lobe pumps to the world's most demanding markets.

DESIGN FEATURES

MOST STRINGENT HYGIENIC STANDARDS

Flush rotor fixing screws are sealed to prevent product ingress. Contoured rotor case internals for full drainability during SIP and shaft seals set up front where the pumping action is! Fully conforming to 3A 02-10 Hygienic Standards and utilizing materials which meet FDA requirements. Versions are available that have been tested and approved to the EHEDG (European Hygienic Equipment Design Group), CIP and SIP protocols and USDA, 3A certification.

LOW MAINTENANCE COSTS

Front loaded single shaft seals are fully accessible from the front of the pump without disturbing the process pipework. Simple bearing assemblies easily pre-set using automotive technology. Bi-wing rotors require no timing adjustments. Even the pump casing is removable, a feature not normally associated with other bi-wing rotor pumps.

HIGH VOLUMETRIC EFFICIENCY

The bi-wing rotors incorporate the low viscosity efficiency associated with circumferential piston pumps with the viscous product handling capability of tri-quad and bi-lobe rotor pumps at an affordable price.

RUGGED DESIGN

Hy-Line design utilizes extremely large shaft diameters mounted in high specification taper roller bearings, fitted into an extremely rigid central pillar made from a high grade alloy. This is all enclosed in an oil filled housing made from the same alloy. These, together with wide tipped rotor wings, which adds another dimension to security, avoid premature pump failure due to overpressure or other abuse.

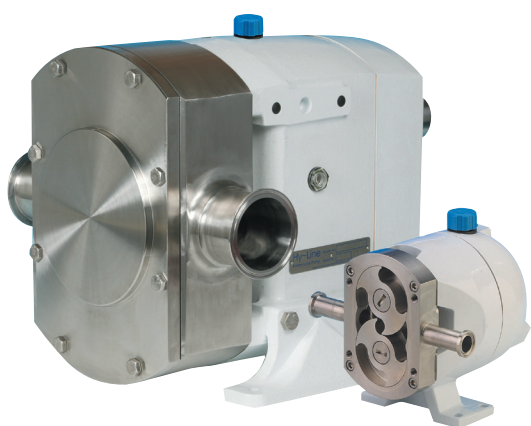

OPTIONS

SEALS

Front loaded single mechanical face type seals of hygienic design. Materials include carbon, stainless steel and silicon carbide.

Low pressure flushed seals utilize the same single mechanical seal with an additional housing. A low pressure flush liquid washes away crystallizing products or liquids which 'skin over'.

Double mechanical seals utilizing all the components from single seals. Used for hazardous, toxic, highly abrasive or sterile products.

Front loaded single O-Ring seals - a low cost seal option used primarily for self lubricating products and products which contain little or no abrasives.

Front loaded double O-Ring seals - suitable for pressurized grease or flushing with a suitable liquid to enable low cost sealing of high sugar confectionery and bakery products.

Multiple PTFE lip seal - complete with controlled release food grade grease injection system, the ideal sealing system for chocolate & other products sensitive to water flush.

CERTIFICATION

3.1B Material Certification package.

3A Variants with Nitrile or EPDM elastomers and port options - Tri-clamp, IDF, 3A, DIN11851

CONNECTIONS

All US and European standards including DIN, SMS, RJT, IDF, Tri-Clamp & BSP. Most pumps available with 2 different sizes, all fully interchangeable. (Not on 3 & 7 size)

ELASTOMERS

Nitrile, Viton, EPDM and PTFE product contact joints available in compounds conforming to 3A Sanitary Standard 18-03 and FDA title 21 section 177.2600.

OTHER OPTIONS

- Pump Head temperature control jackets
- Integral pressure relief valve
- Enlarged suction port for viscous products
- All stainless steel bearing pedestal and cover
- Low carbon 316L pump head
- Tanker pump version for direct hydraulic drive

HY~LINE

Pump Model	LH32	LH34	LH42	LH44	LH52	LH54	LH62	LH64	LH72	LH74	LH76	
Port Size	(mm)	19 or 25	25 or 38	25 or 38	38 or 50	38 or 50	50 or 76	63 or 76	76 or 100	76 or 100	100 or 152	127 or 152
	(inch)	3/4 or 1	1 or 1 1/2	1 or 1 1/2	1 1/2 or 2	1 1/2 or 2	2 or 3	2, 2 1/2 or 3	3 or 4	3 or 4	4 or 6	5 or 6
Displacement	(litre)	3.5	7	12.3	20.4	26.5	45.5	64	95	123	205	301.5
	(100 revs) (US gal)	0.92	1.85	3.25	5.39	7.00	12.02	16.90	25.10	32.50	54.15	79.65
Max Flow	(litre)	52	105	123	204	265	455	461	684	836	1230	1809
	(per min) (US gal)	13.7	27.7	32.5	53.9	70.0	120.2	121.8	180.7	220.8	324.9	477.9
Max Pressure	(bar)	15	8	15	8	15	8	15	8	15	8	5
	(psi)	217	116	217	116	217	116	217	116	217	116	72
Max Speed	(RPM)	1500	1500	1000	1000	1000	1000	720	720	680	600	600
Size LxBxH	(mm)	213x192x166	229x192x166	274x223x196	290x223x196	386x249x208	414x259x213	460x270x311	464x302x311	486x380x363	526x386x363	573x412x363
	(inch)	8.25x7.5x6.5	9x7.5x6.5	10.75x8.75x7.75	11.5x8.75x7.75	15.25x9.75x8.25	16.25x10.25x8.25	18.25x10.75x12.25	18.25x11.75x12.25	19.25x15x14.25	20.75x15.25x14.25	22.5x16.25x14.25
Bareshaft Weight	(kg)	8	10	18	20	32	35	61	65	125	145	165
	(lbs)	18	22	40	44	70	77	134	143	275	319	363
Temp	(°C)	-30 to 140										
	(°F)											
Viscosity (cP)	1 to 1 million											

CONSTRUCTION DETAILS

1. Flush fitting, sealed rotor retaining screws avoid build up of stagnant product as no end cover recesses are required and no product can get into the rotor drive.
2. Front mounted shaft seals for easy replacement and full accessibility of CIP liquids.
3. Rugged, high grade alloy bearing pedestal and housing for low weight and high strength, completely encased in epoxy coating.
4. Detachable ports for maximum flexibility in connection type and size. (Not on 3 & 7 size).
5. Removable feet allow quick change for pump mounting in the ideal orientation. (Not on 3 & 7 size).
6. High specification taper roller bearings give over one million hours life on a typical duty.
7. Precision cut spur gears for high load capability and ease of maintenance.
8. Fully interchangeable bi-wing rotors can be fitted without the need to re-time thus reducing downtime and allows pump to cope with a higher level of abuse.
9. Heavy duty shafts for high pressure capability.

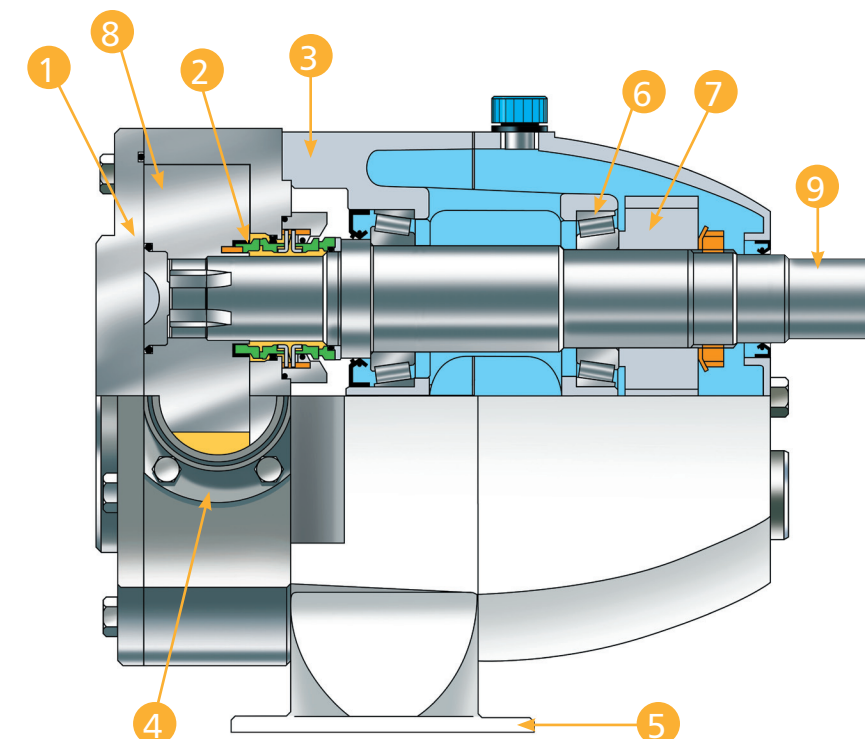



24 SERIES HYGIENIC POSITIVE DISPLACEMENT PUMP

The 24 Series range of positive displacement rotary lobe pumps is a proven design spanning over 20 years. With thousands of pumps in use around the world, users agree that it is one of the best designed hygienic pumps on the market today. The 316 Stainless Steel 24 Series pump range incorporates improved technology in hygienic pump design and manufacturing techniques, yet utilizes the traditional tri-lobe rotor concept, which is so well accepted by the world's leading suppliers of Food, Personal Care and Chemical products.

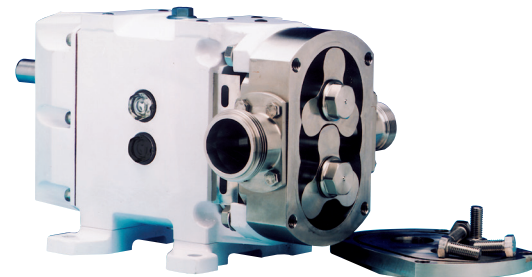

DESIGN FEATURES

ADAPTABILITY

This is the key design concept. The pump utilizes 'bolt on' features which allow quick and easy interchange of parts to enable exact specification of the pump to suit any application from stock!

RUGGED DESIGN

The bearing frame design utilizes large shaft diameters mounted in high specification taper roller bearings, fitted into rigid pillars which form an integral part of the high grade alloy housing. These ensure maximum shaft stiffness in order to avoid premature pump failure due to overpressure or other abuse.

LOW MAINTENANCE

The shaft, bearing and gear assemblies are fully immersed in an oil bath to give maximum life even at extremes of operating conditions. The timing gears are easily accessible at the rear of the pump in the unlikely event that re-timing should become necessary. Rotors are all fully interchangeable avoiding the need to re-time which is a problem associated with so many other rotary lobe and circumferential piston pumps.

IMPROVED HYGIENIC TECHNOLOGY

Fully swept pump chamber, together with sealed rotor spline, accessible seals, and approved sealing components, ensure that the pump meets the stringent requirements of major international customers

OPTIONS

SEALS

Single mechanical seals are of hygienic design. Materials include carbon, stainless steel, tungsten carbide and silicon carbide.

Low pressure flushed seals utilize the same single mechanical seal with an additional housing. A low pressure flush liquid washes away crystallizing products or liquids which 'skin over'.

Double mechanical seals utilize all the components from single seals. For hazardous, toxic, highly abrasive or sterile products.

Gland packing - a cost effective general purpose seal for non-hazardous liquids. Used on either a stainless steel or hard chrome plated anti-wear sleeve.

O-Ring seals - another low cost seal option used primarily for self lubricating products such as dairy products.

CERTIFICATION

3A Variants with Nitrile or EPDM elastomers and port options - Tri-clamp, IDF, 3A, DIN11851.

ROTORS

Tri-lobe rotors in stainless steel handle 90% of all applications. The traditional rotor shape gives an excellent combination of efficiency, solids handling, low and high viscous product capability.

Bi-lobe rotor in stainless steel for exceptional handling of delicate, soft solids such as fruit pieces and vegetables.

Rubber covered tri-lobe rotor to cope with small hard solids such as small bone fragments or ice crystals.

CONNECTIONS

All US and European standards including DIN, SMS, RJT, IDF, Tri-Clamp & BSP. Most pumps available with 2 different sizes, all fully interchangeable.

ELASTOMERS

Nitrile, Viton, EPDM, PTFE or Kalrez product contact joints are available.

OTHER OPTIONS

Pump head temperature control jackets.
Integral pressure relief valve.
Enlarged suction ports for highly viscous product.

24 SERIES

Pump Model	S2	A1	A2	B1	B2	C1	C2	D1	D2	E2	
Port Size	(mm)	25 or 38	25 or 38	38 or 50	38 or 50	50 or 76	50 or 76	76 or 100	76 or 100	152	
	(inch)	1 or 1/2	1/2 or 2	1 1/2 or 2	2 or 3	2 or 3	3 or 4	3 or 4	4	6	
Displacement (100 revs)	(litre)	3.6	10.4	18.6	24.5	37.7	62.3	93.6	122	350	
	(US gal)	0.92	2.75	4.91	6.47	9.96	16.46	24.72	32.23	92.46	
Max Flow (per min)	(litre)	36	100	177	237	362	448	655	793	2100	
	(US gal)	9.2	27.5	49.1	64.7	99.6	118	173	209.5	554.8	
Max Pressure	(bar)	7	15	10	15	10	14	10	12	12	
	(psi)	101	217	145	217	145	203	145	174	174	
Max Speed	(RPM)	1000	960	960	960	960	720	700	650	600	
Size LxBxH	(mm)	261x146x106	335x204x188	355x204x188	408x226x227	428x236x227	538x288x319	564x296x319	623x322x355	647x346x355	770x425x438
	(inch)	10.25x5.75x4.25	13.25x8x7.5	14x8x7.5	16x9x9	16.75x9.25x9	21.25x11.25x12.5	22.25x11.75x12.5	24.5x12.75x14	25.5x13.75x14	30.25x16.75x17.25
Bareshaft Weight	(kg)	10	14	18	29	33	70	75	112	300	
	(lbs)	22	31	40	64	73	154	165	246	660	
Temp	(°C)	-30 to +150	-40 to +200								
	(°F)	-22 to 302	-40 to 392								
Viscosity (cP)		1 to 1 million									

CONSTRUCTION DETAILS

1. Sealed rotor splines ensure improved cleanability.
2. Rugged, high grade alloy bearing frame for low weight and high strength.
3. Detachable ports for maximum flexibility in connection type and size.
4. Removable feet allow quick change for pump mounting in the ideal orientation.
5. High specification tapered roller bearings give over one million hours life on a typical duty.
6. Shaft sleeves under seals ensure minimized maintenance costs.
7. Precision cut helical timing gears for reduced noise and ease of maintenance.
8. Wide variety of interchangeable seal types to suit many applications.
9. Fully interchangeable rotor options can be fitted without the need of re-timing thus reducing downtime.
10. Heavy duty shafts for high pressure capability and minimum deflection.

