



GEAR PUMPS



JUNIOR GEAR PUPPY

Gear pumps are ideal for the transfer of hydraulic and light oils, water and Diesel fuel. They are 12 or 24V DC powered making them suitable in automotive, bus and truck applications.

FEATURES

- Medium duty pumps for general purpose use.
- Maximum viscosity 150 Cs
- Inlet filter included
- Simple design means fewer wearing parts
- 3.6 gpm (13.5 lpm) output @ 16.4ft (5m) head
- Self priming to 3 ft (1.0m)
- Ideal for water, oil and diesel transfer



DIMENSIONAL DRAWING

UNLESS OTHERWISE STATED DIMENSIONS IN [] ARE IN MM.

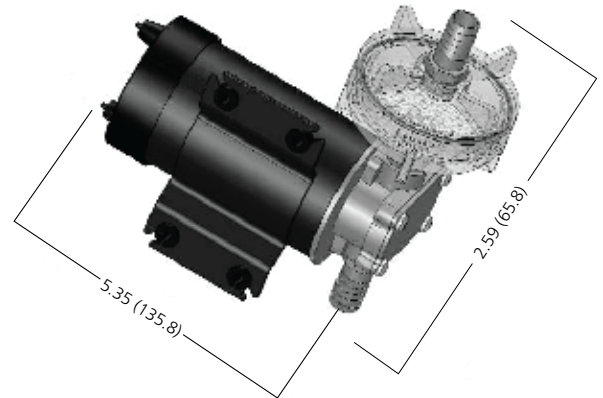

MODELS

MODEL #S	CE	VOLTAGE
23220-2012	Yes	12Volts DC
23220-2024	Yes	24Volts DC



GEAR PUPPY

FEATURES

- Medium duty pumps for general purpose use.
- Maximum viscosity 150Cs
- Inlet Filter Included.
- Simple design means fewer wearing parts.
- Ideal for water, oil and diesel transfer.
- Meets USCG 183.410



DIMENSIONAL DRAWING

UNLESS OTHERWISE STATED DIMENSIONS IN [] ARE IN MM.

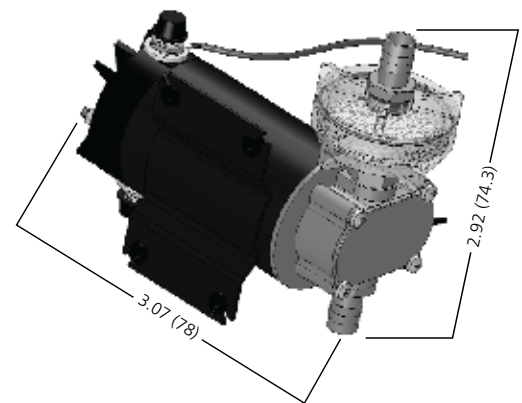

MODELS

MODEL #S	CE	VOLTAGE
23230-2012	Yes	12Volts DC
23230-2024	Yes	24Volts DC