

SELF-PRIMING PUMP FEATURES

Body:	Bronze
Impeller:	Jabsco Neoprene Compound
Shaft:	316 Stainless Steel
Shaft Seal:	Lip Type
Ports:	3/4" NPT
Weight:	6 lb (approx.)

APPLICATION

Marine Engine Cooling

FOR ENGINE MODELS

CHRIS CRAFT - M Series (131 to 158 HP)
 PALMER - DH 120
 KERMATH - Sea Rover
 LATHROP - LH Master-LH6-LH - Atom
 OSCO - Hercules Diesel 685
 UNIVERSAL - Super 6-Model Z
 HERCULES - JX
 (and others)

INSTALLATION INSTRUCTIONS

Engage shaft with drive tang, make sure flange seats squarely on mounting surface and bolt to engine. Connect inlet and outlet fittings using pipe compound to seal threads.

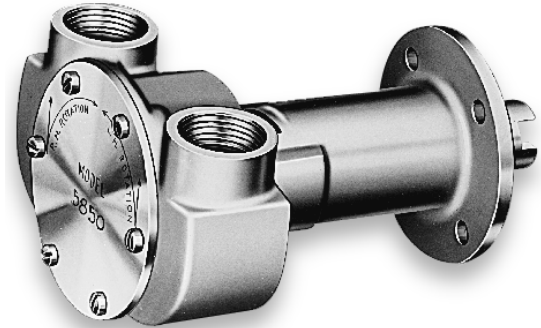

Model 5850-0001

OPERATING INSTRUCTIONS

Pump will self-prime at low or high speeds. Make sure scoop and inlet line are clear and all connections airtight. Do not run pump dry for more than 30 seconds. Lack of water flow may damage impeller. To drain pump, loosen end cover screws.

SERVICE INSTRUCTIONS

IMPELLER REPLACEMENT: Remove end cover and gasket. Pull impeller out by grasping hub or blades with pliers. Replace impeller, gasket and end cover. A light coating of grease in impeller bore will aid priming on dry start up. (Use correct Jabsco gasket, a thicker or thinner gasket may cause impeller damage.) Standard gasket is 0.010" thick.

DIMENSIONAL DRAWING

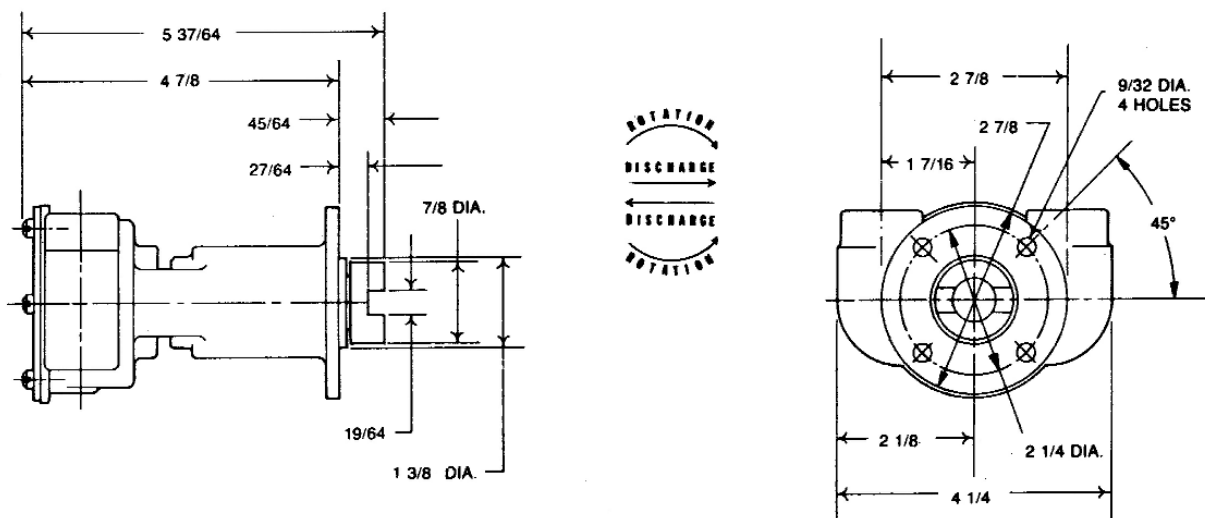

EXPLODED VIEW

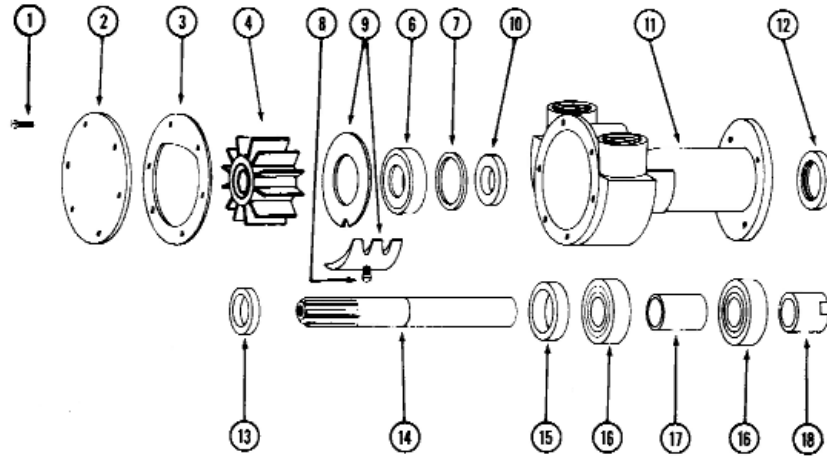

MAJOR REPAIR: Remove pump from engine to replace seal, bearings or shaft. To disassemble pump, remove end cover, gasket and impeller as outlined above. Press on impeller end of shaft to remove shaft and bearing assembly. Remove cam and wearplate assembly. Use screw driver to pry bearing seal out of bearing bore. Press shaft seal out towards impeller bore. Replace all worn parts. When installing coupling, support splined end of shaft. Press bearing seal in bearing bore with lip towards bearing. Press shaft and bearing assembly into bearing bore. Press adaptor ring into body. Install slinger on shaft. Install seal spacer in seal cavity. Install O-ring in seal bore. Press seal in seal cavity with lip facing toward impeller bore. Apply a thin coat of sealant to top of cam and cam screw threads, install wearplate and cam assembly. (Be sure cam is flush with end cover surface.) Secure with screw. Lubricate impeller bore, install impeller. Lubricate impeller face, install gasket and end cover and secure with screws.

PARTS LIST

Key	Description	Qty.	Part Number
1	Screw (End Cover)	6	91002-0020
2	End Cover	1	11830-0000
3*	Gasket	1	3298-0000
4*	Impeller	1	1210-0001
5*	Seal (Shaft)	1	92700-0060
6*	O-Ring †	1	92000-0210
7*	Cam Wearplate Assembly	1	91003-0010
8	Screw (Cam)	1	7884-0000
9	Seal Spacer	1	3166-0000
10	Body	1	
11	Adaptor Ring	1	3376-0000
12	Slinger	1	3286-0000
13	Shaft	1	5857-0000
14	Bearing Seal	1	92700-0060
15	Ball Bearing	2	92600-0130
16	Bearing Spacer	1	3383-0000
17	Coupling	1	3278-0000
18	Service Kit	1	90033-0001

* Parts Contained in Service Kit

† O-ring used only in pumps manufactured prior to June 1993.

PUMP FLOW CHART

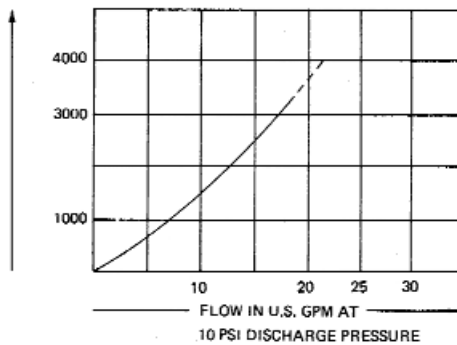

Jabsco



ITT Industries

Jabsco, 20 Icon, Foothill Ranch, CA 92610

Tel : +1 949 859 4945

Fax : +1 949 859 1153

USA

Jabsco, Bingley Road, Hoddesdon, Hertfordshire, EN11 0BU

Tel : +44 (0) 1992 450 145

Fax : +44 (0) 1992 467 132

UK

Fluid Products Canada, 55 Royal Road, Guelph, Ontario N1H 1T1

Tel : +1 519 821 1900

Fax : +1 519 821 5316

CANADA

NHK Jabsco Co Ltd, 3-21-10, Shin - Yokohama, Kohoku-ku, Yokohama 222

Tel : +81 (0) 45 475 8906

Fax : +81 (0) 45 475 8908

JAPAN

Jabsco GmbH, Oststraße 28, 22844 Norderstedt

Tel : +49 (0) 40 53 53 73 0

Fax : +49 (0) 40 53 53 73 11

GERMANY

Warranty: All products of the company are sold and all services of the company are offered subject to the company's warranty and terms and conditions of sale, copies of which will be furnished upon request. The information provided herein is for guidance only, it does not constitute a guarantee of the performance or specification of any individual product or component.

©Copyright 2002 ITT Industries

43000-0202 Rev: 01/03