



Model 34600-Series

ELECTRIC BILGE PUMPS

FEATURES

- Self-Priming
- Diaphragm Design Allows Dry Running
- Quiet Operation
- Large Surge Chamber for Even Water Flow
- Permanently Lubricated Ball Bearings on Shaft and Connecting Rod
- Large Vibration Absorbing Pads
- Corrosion Resistant Materials Throughout for Sea Water Service

This pump meets the following US Coast Guard Regulations:

- Meets USCG Regulation 183.410 and ISO 8846 MARINE for Ignition Protection.
- Flow Requirements (Title 46, Chapter 1, Subchapter T, Section 182.25-10) for Small Passenger Vessels.

This pump listed as NMMA accepted.

SPECIFICATIONS

- Open Flow:** 10.8 GPM
Vert. Dry Suction Lift: 10 feet (3 m)
Ports: 1" Slip-on Hose
Weight: 13 lb (5,9 kg)

APPLICATION

Jabco diaphragm pumps are self-priming so that they can be mounted above and outside of harsh bilge environments. Because they are mounted remotely, the intake hose can be routed to the lowest point of the bilge regardless of space limitations. The reliable diaphragm design is not damaged by dry running.

INSTALLATION

MOUNTING

Pump must be mounted in a dry location, the motor is not waterproof. Selection of a dry, cool ventilated location will generally extend pump life. Adjust belt tension for 1/4 inch play between pulleys.

PLUMBING

For intake and discharge use 1" ID non-collapsible hose. Keep intake and discharge lines free of kinks and restrictions. For separate pump-out of fore and aft bilge compartments, use ball valves to shut off dry compartments.

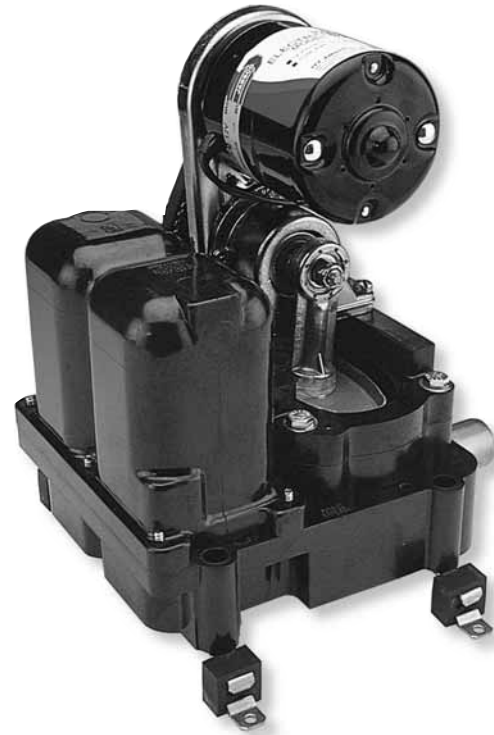

Model: 34600-Series

Use a 1" bilge strainer (Model 35890-0010) in the intake line from the bilge to protect pump from debris.

WIRING - DC VOLTAGE MODELS

Wire pump in a circuit independent of all other electrical fixtures. Use stranded copper wire. Install fuse/breaker in positive circuit. See table for recommended wire and fuse size. See diagram for wiring connections. Use a 10 amp-rated switch (Model 44960-0000). After installation, it is recommended that voltage be checked at the motor terminals with motor operating under full load and all other appliances in the circuit operating. Voltage should not be less than 90% of rated motor voltage.

Standard Models

Model No.	Voltage	Amperage Nominal
34600-0000	12 Vdc	9.5
34600-0010	24 Vdc	4.5
34600-0031	115 Vdc	1.0

WIRING DIAGRAM FOR MANUAL-AUTOMATIC OPERATION

3-WAY SWITCH
NO. 96070-0110
OR 44960-0000
OR 44960-0001

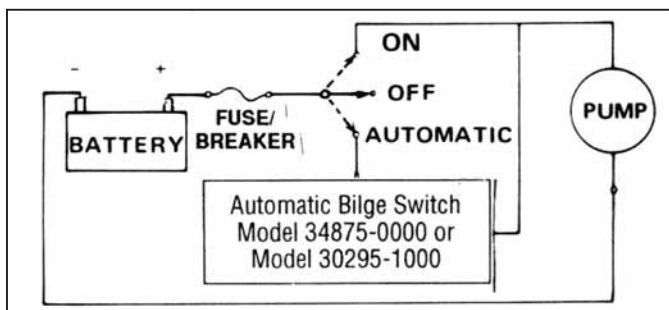

WIRING - AC VOLTAGE MODEL

Use 16 gauge standard copper wire for lengths up to 100 feet from power source. Connect the grounded, unswitched conductor (white) to the white motor lead. Connect the ungrounded switched conductor (black) to the black motor lead. This conductor should include, at the power source, a 1.5 amp 125 Volt fuse. The green motor lead must be connected to the AC circuit ground.

MINIMUM WIRE SIZES

Model Number	Voltage	Wire Size for Length of Run		Fuse/Breaker*
		1-25'	25-50'	
34600-0000	12 Vdc	12 AWG	10 AWG	15 amp
34600-0010	24 Vdc	14 AWG	14 AWG	8 amp
34600-0031	115 Vdc	16 AWG	16 AWG	1-1/2 amp

*Customer supplied, not included with pump.

MAINTENANCE

WINTER STORAGE:

When possible, it is preferred that the complete pump or at least motor, diaphragm and valves be removed and stored in a warm dry place. If this is not possible, the pump must be completely drained, hoses removed and pump run until all water is expelled.

SERVICE

DIAPHRAGM AND CONNECTING ROD REPLACEMENT

1. Remove four tie down bolts.
2. Lift jack shaft and the attached diaphragm assembly from pump base.
3. Remove two diaphragm retainer screws and the bottom diaphragm retainer.
4. Remove nut holding connecting rod to jackshaft. Remove connecting rod and diaphragm from the top diaphragm retainer, then unscrew bolt to separate diaphragm and plates.

5. Check diaphragm for cuts and cracks. Check rod assembly bearing for excessive wear. Replace if badly worn.
6. Loosely reassemble diaphragm, diaphragm plates, connecting rod spacer and diaphragm bolt onto connecting rod.
7. Firmly secure connecting rod to jack shaft with the lock nut. Secure diaphragm to upper diaphragm retainer with the bottom diaphragm retainer and two screws.
8. Tighten connecting rod bolt.
9. Replace motor-mount-diaphragm assembly and fasten evenly to base with the four tie down bolts and washers.

VALVE REPLACEMENT

1. Turn off power to pump. Remove four tie down bolts.
2. Expose valves by lifting jack shaft and attached diaphragm assembly from pump base. Remove and clean or replace valves.
3. Install valves, making sure rubber flapper is UP on intake and DOWN on discharge.
4. Replace motor-mount-diaphragm assembly and fasten evenly to base with the four tie down bolts and washers.

SURGE CHAMBER GASKET REPLACEMENT

1. Remove six surge chamber screws and lift off the surge chamber. Remove and replace two gaskets.
2. Replace the surge chamber and six screws. Tighten evenly to ensure an air and water seal.
3. Reinstall and reconnect power leads.

JABSCO MARINE SWITCH PANELS



44960-0000
LIGHTED SWITCH
W/BOOT SPDT

(DC APPLICATIONS ONLY)



44960-0001
UNLIGHTED
SPDT

(AC OR DC APPLICATIONS)

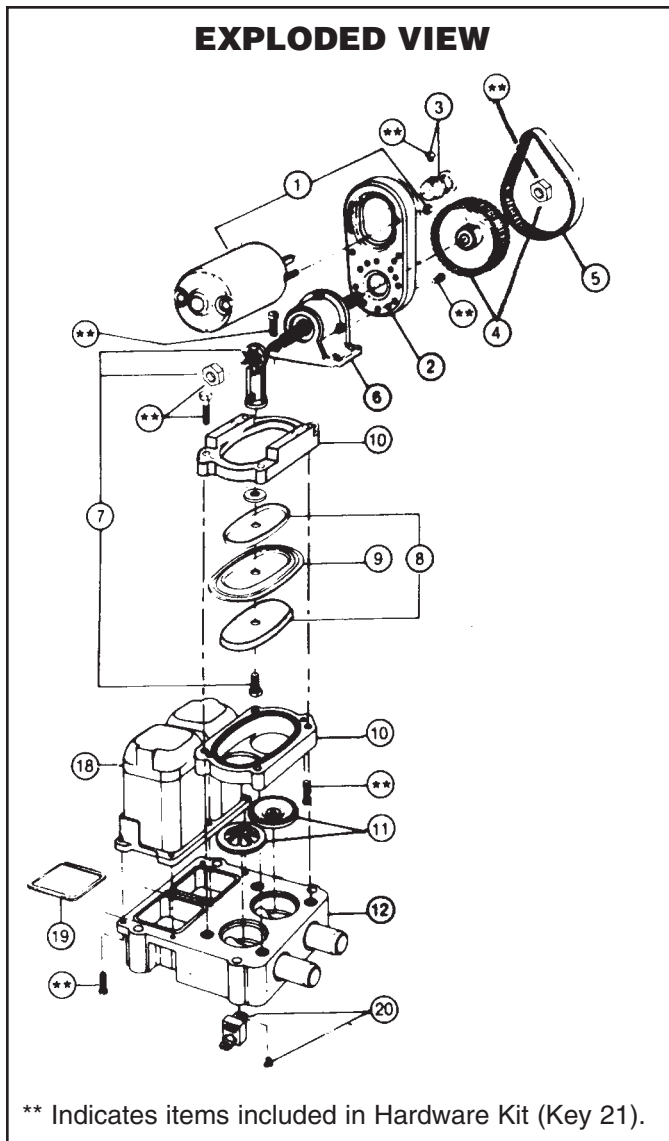

PARTS LIST

Key	Description	Part Number	Qty.
1	Motor Kit 12 Volt dc	30200-0000	1
	Motor Kit 24 Volt dc	30200-0010	
	Motor Kit 115Volt ac.	30200-0031	
2	Motor Mount	34628-0000	1
3	Small Pulley	37169-0000	
4	Large Pulley	37170-0001	
5	Belt	30021-0000 *	1
6	Jack Shaft Assembly	35037-0001	-See note
7	Connecting Rod Kit	37172-0001	-See note
8	Diaphragm Plates	34640-0060	-Top 1
		34637-0000	
9	Diaphragm	30012-0000	1
10	Retainer	34633-0000	-Top 1
		34634-0000	-Bottom 1
11	Valve Set (inlet & outlet)	30002-0000	*† (set) 1
12	Base Assembly†	34623-0000	† 1
18	Surge Chamber	34635-0000	
19	Gaskets	37181-0000	(set) 1
20	Vibration Pad Kit	37180-0000	† (set) 1
21	Hardware Kit	37164-0001	(set) 1
	Service Kit*	30101-0000	

*Indicates parts contained in service kit.

† Indicates parts supplied with base assembly.

NOTE—Jack shaft assembly kit, with part number ending in -0001 includes new style connecting rod (37173-0001) with a 5/16" diameter hole and two (2) locknuts. Previous model pumps use a connecting rod (37173-0000) with a 1/4" diameter hole and a bolt.

TROUBLESHOOTING

Problem

Loss of suction to pump

Solution

Air leak in suction line.
 Bilge pickup not submerged.
 Intake hose kinked or plugged.
 Fouled intake or discharge valve.

Rough or noisy operation

Intake or discharge hose kinked or plugged.
 Pump not mounted firmly.
 Loosened eccentric screw.

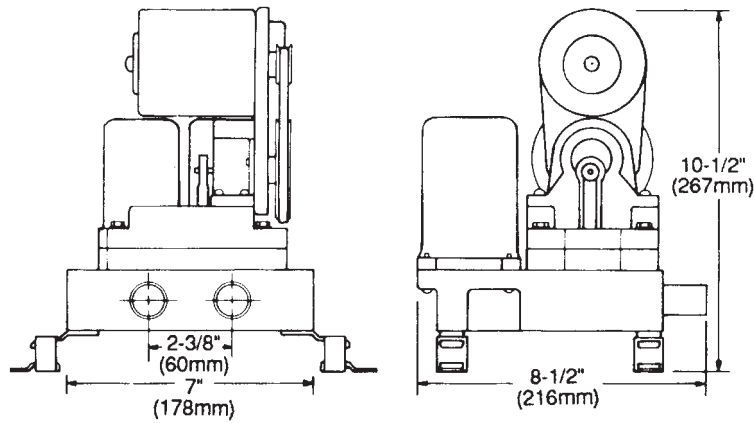

THE PRODUCTS DESCRIBED HEREIN ARE
SUBJECT TO THE JABSCO ONE YEAR LIMITED
WARRANTY, WHICH IS AVAILABLE FOR YOUR
INSPECTION UPON REQUEST.

**For more information
visit us online at www.jabsc.com**