



# MAXI PUPPY 3000

## MODELS:

23610-3003 12V

23610-3103 24V



## FEATURES:

Continuous rated, heavy duty pumps for bilge and general purpose use.

- ISO 8846 MARINE (Ignition protection).
- ISO 8849 MARINE (Bilge pump standard).
- Small bilge debris present no problem to these bronze bodied, flexible impeller pumps.
- Simple design means fewer wearing parts.
- 44 lpm (9.5 UK gpm) output @ 3m (10ft) head.
- Self priming to 2.4m (8 ft).

## MAXI PUPPY 3000 PERFORMANCE

Approximate performance for new pump, running water at 20°C with fully charged battery

TOTAL HEAD		MAXI PUPPY 3000	
m	ft	lpm	UK gpm
2	7	45	10
4	13	42	9
6	20	38	8.4
8	26	34	7.5
10	33	30	6.6
12	39	25	5.5

## INSTALLATION INSTRUCTIONS:

Jabsco Maxi Puppy 3000 can be mounted on any flat surface. Fit the pump in a dry, well ventilated position where there is full access for service. If installed in a vertical position the motor must be above the pump head. Use the rubber grommets provided to minimise vibration, do not overtighten the mounting screws.

Secure 25mm (1") id hose either direct to the discharge ports or to ½" BSP male threaded fittings using stainless steel hose clamps. Use spiral reinforced hose (with a smooth internal bore) that will not collapse under suction, or rigid or semi rigid pipework systems. The pipework must be compatible with the liquid being pumped. Pipe runs should be kept as straight and short as possible, avoiding rising and dipping over obstructions. Fit a strainer on the inlet hose to prevent larger debris from entering the pump.

## WIRING INSTRUCTIONS

Make all electrical connections in dry locations, connections in humid environments should be sealed to prevent corrosion. Protect the circuit with a correctly rated fuse or circuit breaker in the red positive (+) lead as close as possible to the power source. Connect the black motor wire to the negative (-) battery terminal. Inadequate voltage at the motor terminals when the pump is running (not less than 10% below rated voltage at full load) due to partially discharged batteries or insufficient cable size may result in blowing fuses, failure to start or poor pump performance.



**WARNING:** If the fuse fails repeatedly do not fit a heavier fuse or bridge the fuse terminals with silver paper or metal wire. Failure to observe this instruction may result in a fire hazard due to overheating of cables.



**WARNING:** Do not use any Jabsco pump for petrol, petroleum products or any products with a flash point below 37°C (98°F), explosion or death may occur.



**WARNING:** All marine pumps discharging overboard must be installed with the overboard discharge well above both static and heeled waterlines.



ELECTRICAL WIRING INFORMATION					
MODEL NO.	VOLTAGE	MAXIMUM AMP DRAW	MAXIMUM FUSE SIZE	MINIMUM WIRE SIZE	MAXIMUM LENGTH BETWEEN (+) & (-) BATTERY TERMINALS
23610-3003	12 volt	21 amp	25 amp	84 / 0.30mm (6mm <sup>2</sup> )	4.5M
23610-3103	24 volt	11 amp	15 amp	50 / 0.30mm (4mm <sup>2</sup> )	4.5M

\* For longer installations, fit thicker cables

## DIMENSIONAL DRAWING & PARTS LIST

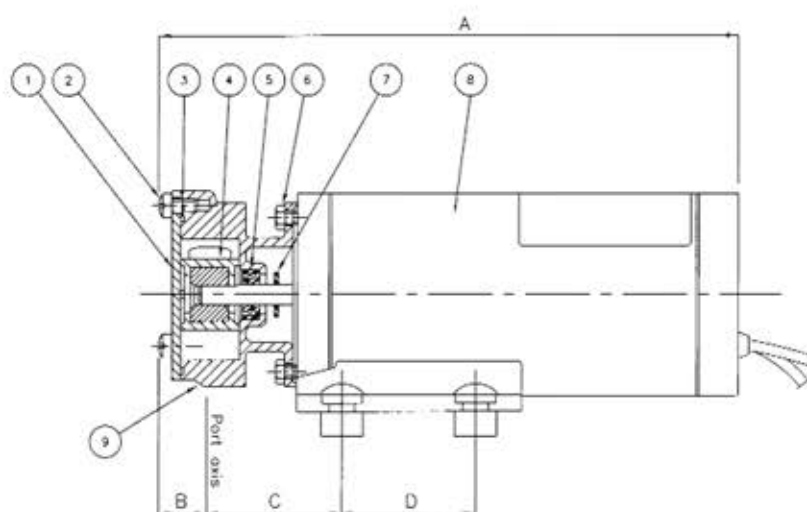
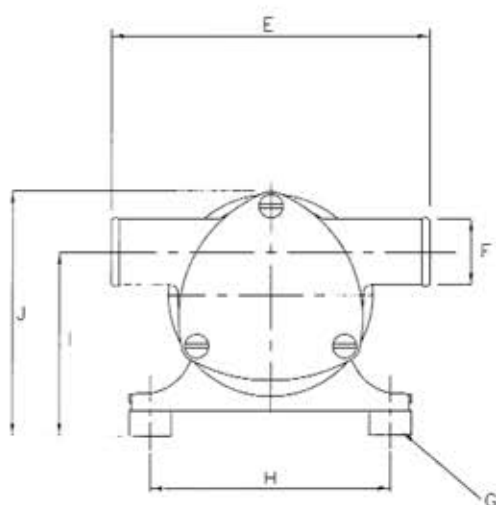

### DIMENSIONS IN MILLIMETRES

A	B	C	D	E	F	G	H	I	J
220	19.5	50	50.8	120	Ø25	Ø6	91	69.6	93

WEIGHT: Maxi Puppy 3000 - 3.4kg (7.4lb)

### MAXI PUPPY 3000 PARTS LIST

KEY	DESCRIPTION	QUANTITY	PART NUMBER
1	End Cover	1	9328-0200
2	End Cover Screw*	3	SP1004-09
3	O' Ring*	1	X5251-049
4	Impeller*	1	7273-0203
5	Seal*	1	SP2701-52
6	Screw (pump to motor)	2	X3001-147F
7	Slinger	1	6342
8	Motor 12V	1	98012-0159C
	Motor 24V	1	98012-0160C
9	Body	1	23064-2200
	Service Kit (Contains items marked *)		SK224-01

**Jabsco**

**Jabsco**, 1 Kondelin Road, Cape Ann Industrial Park, Gloucester, MA 01930

Tel : +1 978 281 0440 Fax : +1 978 283 2619

**Jabsco**, Bingley Road, Hoddesdon, Hertfordshire, EN11 0BU

Tel : +44 (0) 1992 450 145 Fax : +44 (0) 1992 467 132

**Fluid Products Canada**, 55 Royal Road, Guelph, Ontario N1H 1T1

Tel : +1 519 821 1900 Fax : +1 519 821 5316

**NHK Jabsco Co Ltd**, 3-21-10, Shin - Yokohama, Kohoku-ku, Yokohama 222

Tel : +81 (0) 45 475 8906 Fax : +81 (0) 45 475 8908

**Jabsco GmbH**, Oststraße 28, 22844 Norderstedt

Tel : +49 (0) 40 53 53 73 0 Fax : +49 (0) 40 53 53 73 11

**Jabsco Italia, S.r.l.**, Via Tommaseo, 6, 20059 Vimercate, Milano

Tel : +39 039 685 2323 Fax : +39 039 666 307

USA

UK

CANADA

JAPAN

GERMANY

ITALY

Warranty: All products of the company are sold and all services of the company are offered subject to the company's warranty and terms and conditions of sale, copies of which will be furnished upon request.

©Copyright 2004

www.jabsco.com

43001-0591 rev 02/2004 qxd