



Model 18840-Series

SELF-PRIMING PUMPS ENGINE COOLING

FEATURES

Body:	Bronze
Bearing Housing:	Bronze
Impeller:	JabSCO Neoprene Compound
Shaft:	Stainless Steel
Shaft Seal:	Carbon Ceramic Face Type
Bearings:	Sealed Ball Bearing
Pulley:	6-1/2" "A" Size Belt
Ports:	1" (25.4mm) ID Hose
Weight:	7 lb (3.2 kg)

VARIATIONS AVAILABLE

MODEL NO.	DESCRIPTION
18840-0010	Includes 6-1/2" "A" belt pulley
18840-1010	Includes 6-1/2" "A" belt pulley and high pressure impeller**
Nissan LDM	4 cylinder

APPLICATION

Marine engine cooling

INSTALLATION AND OPERATION

The pump may be mounted in any position. The direction of rotation of the pump determines the location of the intake and discharge ports (refer to dimensional drawings). Before installing, rotate the pump shaft in the direction of the normal operating rotation of the engine that the pump will be mounted on. The mounting bracket used to support the pump must be designed to enable adjustment of the pump position for proper drive belt tension.

Attach the pump to the mounting bracket using 3/8" x 16 hex head screws. The pump mounting holes are tapped to this thread size.

Put pulley drive belt over both the drive pulley and the pump pulley. An "A" section pulley belt should be sufficient to drive the 18840-Series pump. Position the pump to allow 1/2" deflection of the drive belt midway between the engine and pump pulleys. Secure the pump mounting brackets. Attach 1" ID hose to the ports and clamp, using two stainless steel band clamps per port (be sure to attach the water intake line to the proper pump port).

Be sure that all suction lines are airtight so that the pump will self-prime. Start the engine and run at low speed. This pump depends on the water for lubrication. Do Not Run Dry for more than 30 seconds. Lack of water will



Model 18840-Series

damage the impeller. This pump is designed for liquids between 45° and 180°F. Pumping colder water will shorten impeller life.

	WARNING Injury hazard. Exposed pulleys and belts can cause injury. Install shield around pulleys and belts. Stay clear while machinery is operating.
--	--

WINTERIZING

Drain the pump by loosening the impeller housing bolts and loosening the housing. Flush cooling system with an ethylene glycol base antifreeze. **Do not use a petroleum based rust inhibitor in the pump.**

PERFORMANCE

PUMP FLOW CHART

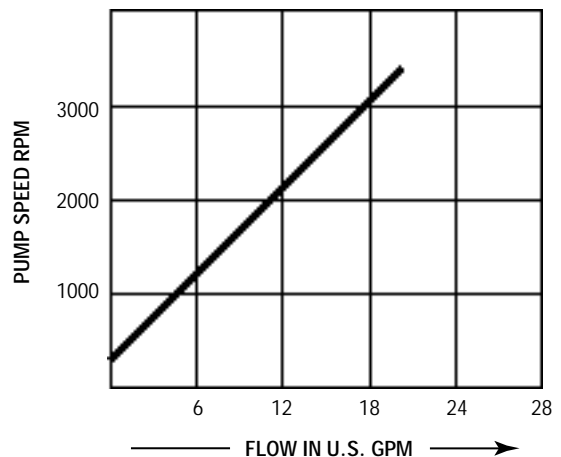

Typical flow in average engine cooling application*

*Average engine cooling applications have discharge pressures of 10-15 psi and inlet vacuums of 3-5 inches of mercury.

**If system discharge pressures range between 15-25 psi, Model 18840-1010 is recommended to maintain flow.

EXPLODED VIEW

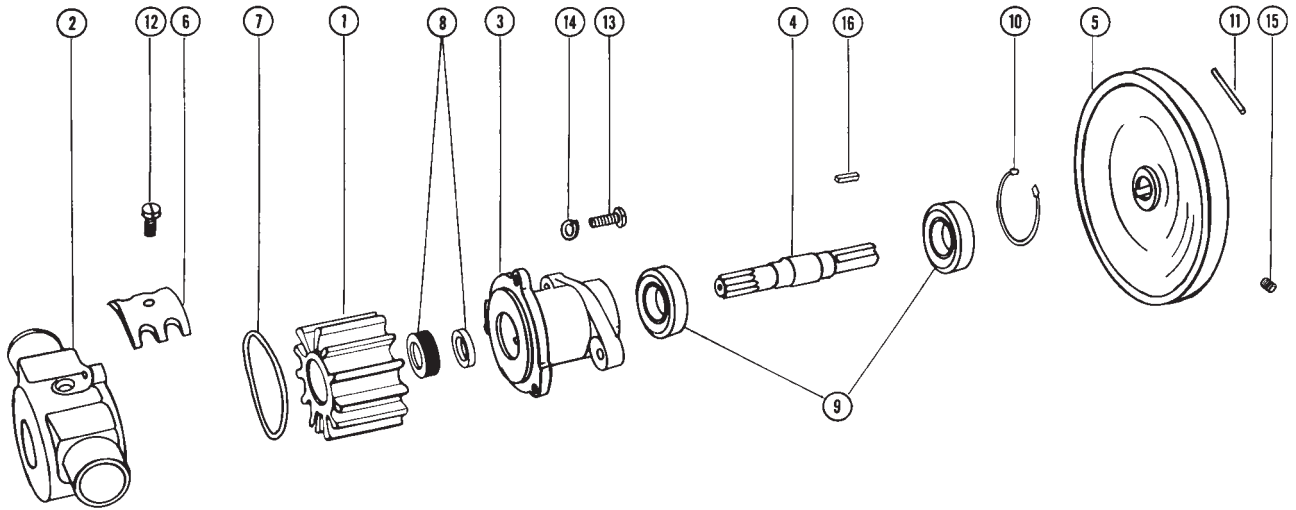

PARTS LIST

Key	Description	Qty.	Part Number
1	Impeller and Spline Seal*	1	
	Model 18840-0010	1	1210-0001
	Model 18840-1010	1	3085-0001
2	Impeller Housing	1	18834-1000
3	Bearing Housing	1	18943-1000
4	Shaft	1	18836-1000
5	Pulley	1	18753-0006
6	Cam	1	490-0001
7	O-Ring*	1	18753-0005
8	Seal*	1	96080-0080
9	Ball Bearing	2	92600-0120
10	Retaining Ring†	1	See Hrdw. Kit
11	Roll Pin†	1	See Hrdw. Kit
12	Cam Screw	1	91003-0010
13	Screw Kit (3 ea. with Washers)	1	18753-0001
14	Split Washer		See Screw Kit
15	Set Screw†	1	See Hrdw. Kit
16	Key†	1	See Hrdw. Kit
	Service Kit(Model 18840-0010)	1	90180-0001
	Hardware Kit	1	18753-0010

*Included in Service Kit

†Included in Hardware Kit

SERVICE INSTRUCTION

DISASSEMBLY

1. Remove the three impeller housing screws (key 13).
2. Slide impeller housing (key 2) off the bearing housing (key 3) and shaft (key 4) assembly.
3. Grasping hub of impeller (key 1) with pliers, remove it from impeller housing.
4. Remove cam screw (key 12) from the impeller housing. Slide the cam (key 6) out of the impeller housing.
5. Remove cam screw (key 12) from the impeller housing. Slide the cam (key 6) out of the impeller housing groove. **TO REMOVE SEAL ASSEMBLY, THE SHAFT AND BEARING ASSEMBLY MUST BE REMOVED FROM THE BEARING HOUSING (KEY 3).**
6. Drive roll pin (key 11) out of the pulley and shaft subassembly.
7. Remove pulley (key 5) and key (16) from shaft.
8. Remove the retaining ring (key 10) out of the bearing housing (key 3).
9. Lightly tap the spline end of the shaft. Shaft and ball bearings (key 9) should slide out of the bearing housing. **BE CAREFUL NOT TO DAMAGE SPLINE END OF SHAFT.**
10. Ceramic portion of the seal (key 8) assembly normally will stay on the shaft. **THE BRASS/CARBON PORTION OF THE SEAL SHOULD HAVE REMAINED IN THE BEARING HOUSING.** Lightly press this portion from the pulley end of the bearing housing toward the impeller end of the bearing housing.
11. Press ball bearings (key 9) off the shaft by supporting each bearing on its inner race to prevent damage.

ASSEMBLY

1. Clean and inspect all components for wear or damage. Replace all components where needed.
2. Lightly lubricate pump shaft (key 4) and press bearings (key 9) onto shaft by applying force to inner race of the bearing. **DO NOT APPLY FORCE TO OUTER RACE OF BEARING.**
3. Slide ceramic (white) portion of seal (key 8) onto spline end of shaft with large white face toward spline end.
4. Lightly press the brass/carbon portion of the seal into the bearing housing (key 3); be careful not to damage the carbon face of the seal. Brass face should face toward impeller end of pump and be pressed flush with bottom of counter-bore.
5. Lightly press shaft, bearing and shaft seal (ceramic portion) subassembly into bearing housing; be careful not to damage shaft end or seal components during this assembly.
6. Replace bearing retaining ring (key 10) into bearing housing.
7. Slide pulley (key 5) onto shaft. Make sure that roll pin hole in shaft lines up with hole in pulley.**
8. Drive roll pin (key 11) into pulley and shaft and tighten set screw.
9. Apply a thin coat of sealant to convex side of cam (key 6) and threads of cam screw (key 12), and fasten cam to impeller housing.
10. Slide impeller (key 1) onto shaft spline and place spline seal in impeller bore.
11. Place O-ring (key 7) into groove in impeller housing and cam subassembly. Lubricate impeller bore. With a twisting motion, slide the impeller housing over the impeller. Be sure the direction the impeller blades are bent matches the direction of normal engine and pump rotation.
12. Fasten impeller housing to bearing housing with the three machine screws and washers (key 13 and 14).
13. **TEST** pump following instructions under **Installation and Operation section.**

**If the roll pin hole cannot be aligned through pulley and shaft, drill a new 1/8" hole for roll pin at an angle 45° from original hole. Center punch pulley hub or file a flat spot on hub to ease start of drilling procedure.

DIMENSIONAL DRAWING - Inches (Millimetres)

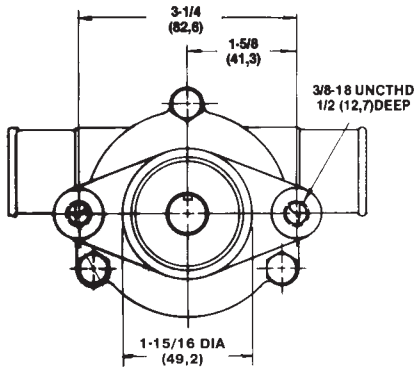

PULLEY NOT SHOWN

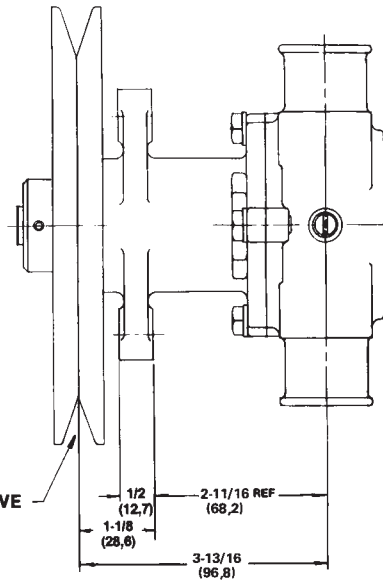

"A" BELT PULLEY GROOVE

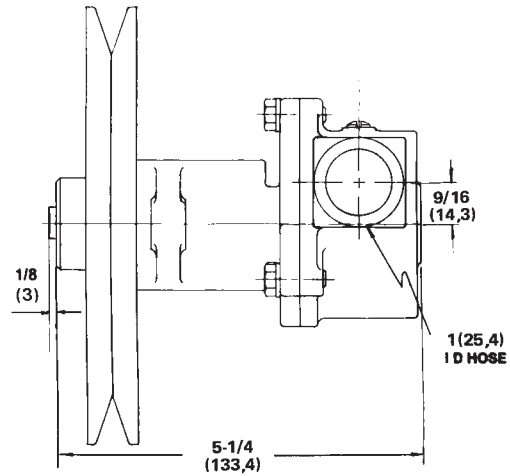
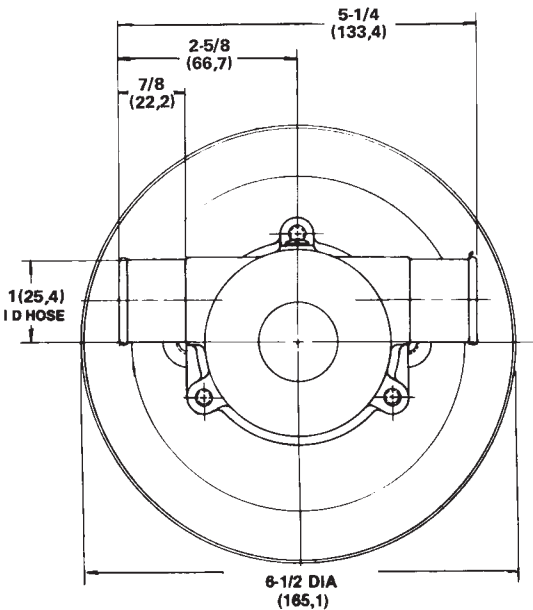
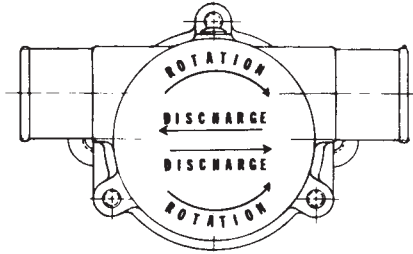

Jabsco



ITT Industries
Engineered for life

THE PRODUCTS DESCRIBED HEREIN ARE SUBJECT TO THE JABSCO ONE YEAR LIMITED WARRANTY, WHICH IS AVAILABLE FOR YOUR INSPECTION UPON REQUEST.

U.S.A.
Jabsco
20 Icon
Foothill Ranch, CA 92610-3000
Tel: 949.609.5106
Fax: 949.859.1254

UNITED KINGDOM
Jabsco
Bingley Road, Hoddesdon
Hertfordshire EN11 0BU
Tel: +44 (0) 1992 450145
Fax: +44 (0) 1992 467132

CANADA
Fluid Products Canada
55 Royal Road
Guelph, Ontario N1H 1T1
Tel: (519) 821.1900
Fax: (519) 821.2569

JAPAN
NHK Jabsco Company Ltd.
3-21-10, Shin-Yokohama
Kohoku-Ku, Yokohama, 222
Tel: 045.475.8906
Fax: 045.475.8908

GERMANY
Jabsco GmbH
Oststrasse 28
22840 Norderstedt
Tel: +49-40-53 53 73 -0
Fax: +49-40-53 53 73 -11