

Service, Safety, Installation and Operating Manual.

Features & Benefits

- Faster refuelling – 60 litres per minute (16 U.S. GPM)..
- Compact easy to install.
- Suitable for "Short Radius" and "Zero Swing" machines.
- Tolerance of small debris (up to 1.0mm diameter).
- 2 Year Warranty (models fitted with Intelligent controller).
- Quick change for fast repair.
- Low maintenance.
- Fully sealed electrics, in conformance to IP67.

Intelligent Control Features...

Failsafe operation:

- Will stop when the tank is full
- Will not start until the pump is immersed in the liquid
- Stops when the drum is empty



Typical Performance

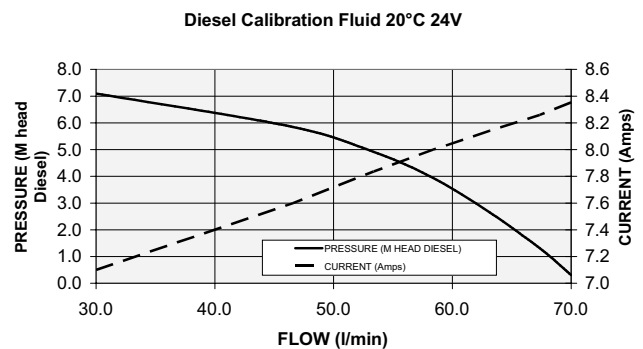

Specifications

Duty Cycle: 10 mins on 5 mins off

Performance Nominal 60 l/min

ATEX:

Ex 112GEx nRfrb T4

Salt Mist:

IEC 60068-2-11:1999: Test Ka

Cold bend (hose only):

BS EN ISO 4672:1999, Method B

Vibration random:

MIL-PRF-28800F, Paragraph 4.5.5.1.1.1, Test (a)

Cold operational:

LR Type Specification No. 1 (IEC 60068-2-1:1990: Tests Ab/Ad)

Dry Heat:

LR Type Specification No. 1 (IEC 60068-2-2:1974: Tests Bb/Bd)

Vibration:

Def-Stan 07-55, Part 2, Section 1/1, Test A2, Paragraph 4 (1) a (i), Level 2

Ingress protection (IPX8):

BS EN 60529:1992

Temperature cycling:

LR Type Specification No. 1 Paragraph 14

Electromagnetic Compatibility:

ISO 13766

Installation Instructions

The Jabsco SR060 Diesel refuelling pump with intelligent controller can be used with or without a float switch. The float switch (when fitted) prevents tank overfill. The controllers are “normally open” circuitry.

Plumbing Connections

- The discharge hose should be connected to the vehicle tank. Discharge entry position into the tank should be above the maximum fuel level point.
- Threaded connection is suitable for G1” (BSP) male 18mm long. Ensure all hose connections are free from leaks.
- The fuel tank must be adequately vented to allow a flow of 60 l/min into it.

Mounting

- The Jabsco SRP060 refuelling pump can be mounted on any surface. We recommend vertical mounting of the pump.
- On intelligent controller models the float switch should be fitted in the vehicle tank. To complete this, a 22 mm diameter hole needs to be cut in the side of the tank within 50 to 100 mm from the top. The float switch is then inserted with the arrow pointing downwards and the bush tightened to give an effective seal, torque 1.7 – 2.0 Nm.
- We recommend using “Pump clamping kit” pt no. SRK060-0010 and “Pump / hose clamping kit” SRK060-0040
- Ensure sufficient space for Hose storage.

Electrical

- A 24Vdc power supply must be available suitable for up to 15 amps and a wire size of at least 16 AWG (1.3 mm²) for cable lengths up to 5.0 metres. The power cables are coloured red + ve and black – ve.
- Make all electrical connections in dry locations.
- On Auto Shut off models the 3 pin connector must be connected to the float switch.
- The pump should always be fused (15 amps).

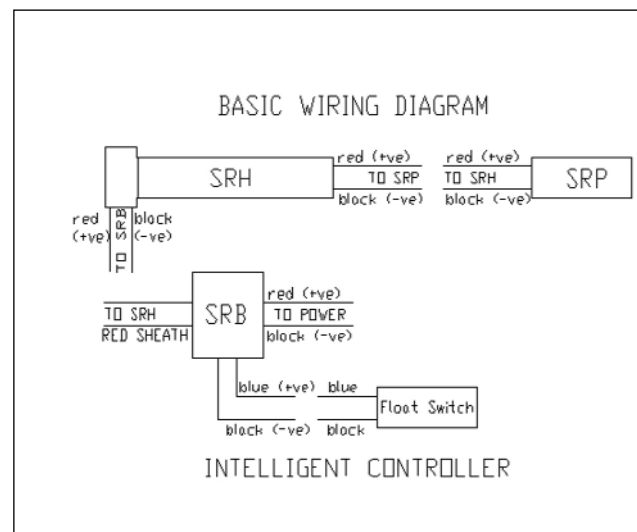

- Remove pump and uncoil hose from storage position in machine.
- Insert the pump and hose into the drum of Diesel fuel or other tank making sure it is fully submerged.
- Push the (I) start button.
- Fuel will now flow from the container into the vehicle tank.
- If the dispensing drum or tank becomes empty the pump should be switched off push the stop (O) button.
- The “Jabsco Intelligent controller” ensures the pump will stop automatically but there is a manual stop which can be used at any time.
- Ensure the pump is off before inserting into a second drum.
- Once refuelling is complete remove the pump from the drum allowing any drips to subside, ensure any residue is wiped before storage. Coil up the hose (minimum radius 150mm) and fit the pump in its storage location.

Information

- This product is designed for use with the Jabsco Intelligent Controller. Usage without this device may negate conformance to the standards listed and invalidate warranty
- The pump will tolerate running dry for up to 10 minutes.
- There is a built in thermal cut-out to prevent the motor from overheating.
- Do not switch the pump on before immersing in the fluid.
- If the pump fails to prime push stop (0), wait for 3 seconds, then start button (1).
- If pump still fails to prime check the vent hole is not blocked. (see drawing)
- Ensure the strainer is always fitted in use.
- Abuse of the product may lead to premature failure and leakage.

Maintenance

- Check the pump and hose for damage and leaks each time it is used.
- Check strainer for damage or blockage.
- Ensure vent hole is not blocked (see drawing)



Dis-assembly

- Unscrew pump from hose. Note; making sure that any fluid is drained into a suitable container.
- Disconnect wires, by holding the two halves of the rubber connector and pulling apart. (see instructions 43010-0266 sup)

Assembly

- Connect wires - (see instructions 43010-0266sup)
- Screw pump onto hose assembly to a torque of 30Nm using two spanners (wrench size 38 mm)

Part Number	Description
SRA060-6115	Pump Assy. 60 l/min 24Vdc, 3m hose, <u>Intell Controller with</u> float switch
SRA060-7115	Pump Assy. 60 l/min 24Vdc, 3.5m hose, <u>Intell Controller with</u> float switch
SRA060-6114	Pump Assy. 60 l/min 24Vdc, 3m hose, <u>Intell Controller without</u> float switch
SRA060-6110	Pump Assy. 60 l/min 24Vdc, 3m hose, <u>no switch</u>
SRB060-0005B	Intell Controller <u>with</u> float switch
SRB060-0004B	Intell Controller <u>without</u> float switch
SRH025-6010B	1" Hose kit: - 3m long hose, (-10°C rated)
SRH025-6040B	1" Hose kit: - 3m long hose, (-40°C rated)
SRH025-7010B	1" Hose kit: - 3.5m long hose, (-10°C rated)
SRH025-7040B	1" Hose kit: - 3.5m long hose, (-40°C rated)
SRP060-0100	Pump unit 60 l/m 24Vdc (spare)
X5020-040	1" Swivel F/M Connector
SRK060-0010	Pump Mounting kit.
SRK060-0040	Hose Mounting kit
SRK060-0030	Strainer kit
92005-6015	Fuse spare

SR060 Submersible Diesel Refuelling Pump

Accessories	Description	Contains
X5020-040	1" Swivel F/M Connector	A
SRK060-0010	Pump Mounting kit.	2 x C+D
SRK060-0040	Hose Mounting kit	B
SRK060-0030	Strainer kit	not shown
92005-6015	Fuse spare	not shown
23529-0502B	Float switch "Camon" connector (spare)	not shown

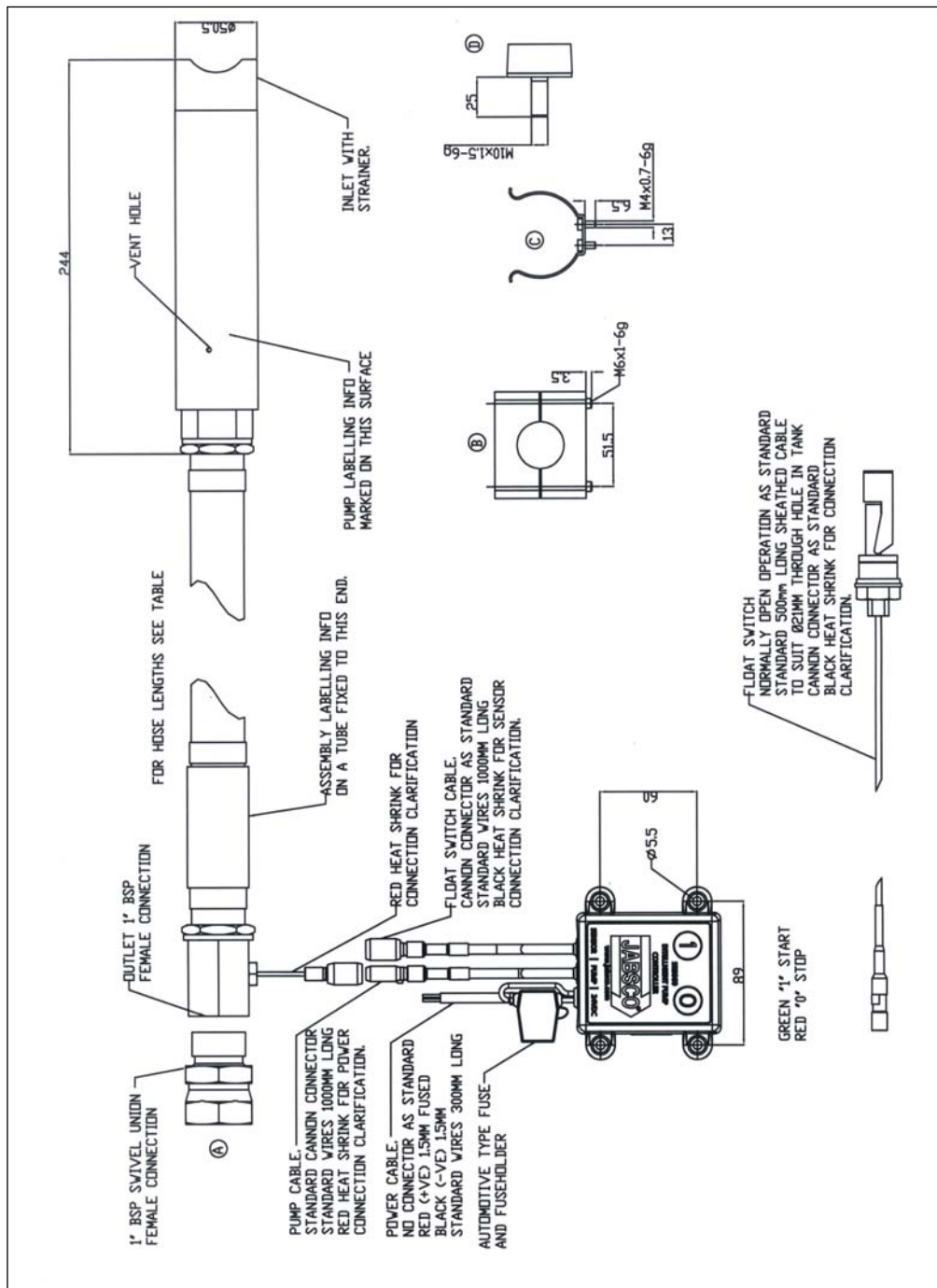

Safety

- This product should be used with the Jabsco Intelligent Controller. If used without, safety could be compromised.
- Do not use this product for petrol, gasoline or any products with a flash point below 37°C (99°F).
- Observe all necessary precautions when handling fuel.
- Avoid spillages.
- Use appropriate personal protective equipment.
- This product is sealed for life, attempts to dismantle could compromise safety And cause electrical faults and leaks.



ITT Jabsco

Bingley Road
Hoddesdon
Hertfordshire
EN11 0BU
England
Telephone (01992) 450 145
International +44 1992 450 145
Fax (01992) 467 132

Declaration of Conformity

Subject	Machinery Directive	98/37/EC
	Electromagnetic Compatibility	BS EN 60945
		BS EN 61000-3-2
		BS EN 55022
		ISO 13766
	CE Marking Directive	93/68/EEC
	WEEE Directive	2002/96/EC
		2003/108/EC
	RoHS	SI 2006/1463
	ATEX	ATEXBaseefa068X0301X

ITT Jabsco declares that the products listed below conform to all relevant parts of the above directives provided they are CE marked.

ITT Jabsco déclare que les produits ci-listés se conforment aux normes CE, dans le cas qu'ils sont marqués avec la plaquette "CE"

ITT Jabsco bestätigt, daß alle unten aufgelisteten Produkte den zutreffenden Teilen der obengenannten Vorschriften entsprechen, vorausgesetzt sie tragen ein CE-Zeichen.

Product Type Submersible Diesel Transfer pumps - DC
SRA060-SERIES
SRB060-SERIES
SRP060-SERIES
SRH060-SERIES
SRK060-SERIES

Signed Engineering Manager

Date 12/1/07.

Quality Manager

Blank Page

**ITT***Engineered for life***Jabsco, 1 Kondelin Road, Cape Ann Industrial Park, Gloucester, MA 01930**

Tel : +1 978 281 0440 Fax : +1 978 283 2619

USA**Jabsco, Bingley Road, Hoddesdon, Hertfordshire, EN11 0BU**

Tel : +44 (0)1992 450145 Fax : +44 (0)1992 467132

UK**Fluid Products Canada, 55 Royal Road, Guelph, Ontario N1H 1T1**

Tel : +1 519 821 1900 Fax : +1 519 821 5316

CANADA**NHK Jabsco Co Ltd, 3-21-10, Shin - Yokohama, Kohoku-ku, Yokohama 222**

Tel : +81 (0) 45 475 8906 Fax : +81 (0) 45 475 8908

JAPAN**Jabsco GmbH, Oststraße 28, 22844 Norderstedt**

Tel : +49 (0) 40 53 53 73 0 Fax : +49 (0) 40 53 53 73 11

GERMANY**Jabsco Italia, s.r.l., Via Tommaseo, 6, 20059 Vimercate, Milano**

Tel : +39 039 685 2323 Fax : +39 039 666 307

ITALY